

320W Constant Voltage Driver



Features

- High efficiency up to 93%
- Built-in active PFC function
- All-Around Protection: OLP, SCP,OVP,OTP
- Waterproof(IP67) and Dry/Damp/Wet Location
- Input Surge Protection:4kV line-line
6kV line-ground
- High Reliability & Long Lifetime & 5 Years Warranty

Applications

- High ceiling, tunnel lights, outdoor lights

■ Approve



◆ Description

VMS-320-XX IP67 L EXC series is a 320W, constant voltage IP67 LED driver that operates from 198-264Vac input with 24V/36V/42V/48V output voltage,excellent power factor and THD feature.With it's dimensions from 227.4 x 68 x 39mm.This series of products is specially designed for direct power supply applications such as high ceiling, tunnel light and outdoor light products.The high efficiency of these drivers and compact plastic case enable them to run cooler, significantly improving reliability and extending product life. To ensure trouble-free operation, protection is provided against input surge, output over load, short circuit, over voltage and over temperature.

◆ Model code

VMS-320-XX IP67 L EXC

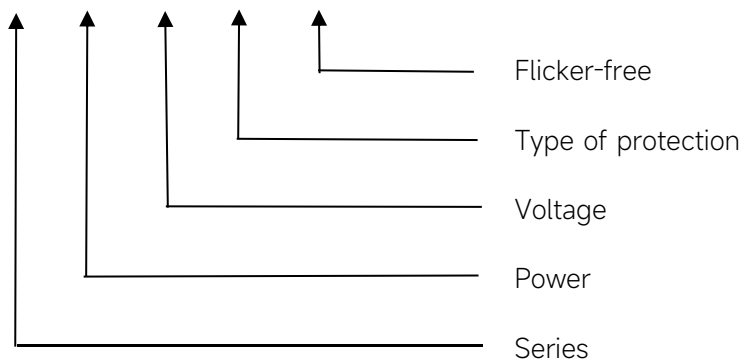

◆ Specification

Output	Constant Voltage	24VDC	36VDC	42VDC	48VDC
	Current Range	0~13.3A	0~8.89A	0~7.62A	0~6.67A
	Unload voltage Max.(VDC)	25.2VDC	37.8VDC	44.1VDC	50.4VDC
	Voltage Accuracy	±5%			
	Output HF current ripple(≥1KHz)	±5%			
	Output LF current ripple(≤120Hz)	±5%			
	SVM	≤0.4			
	P _{st}	≤1			
	Efficiency(Typ.)	92%	93%	93%	93%
Input	Rated input voltage	220-240VAC			
	Range of input voltage	198-264VAC			
	Maximum voltage	300VAC@1 h maximum,unit might not operate in this abnormal condition			
	Frequency(Hz)	50/60 Hz			
	Displacement factor	≥0.95			
	Power Factor	>0.97@Full load,230V			
	Input Current max	1.75A			
	Start-up time	< 0.5S			
	No Load Power	≤0.5W			
	THD (Typ.)	<7%@Full load,230V			
	Protection	Over Load Protection	101-140% YES/Auto Resume		
Over Voltage Protection		36VDC	50VDC	60VDC	63VDC
Short Circuit Protection		YES/Auto Resume			
Over Temperature Protection		YES/Auto Resume			
Capability	Surge capability (L-N)	4KV			
	Surge capability (L/N-Ground)	6KV			
Environment	Operating Temperature	-40°C~+55°C(Details can be seen "Load vs Ta" curve.)			
	Humidity	20%-90%RH			
	Tc	90°C			
	Storage Temperature	-40°C~+85°C			
	Life time	> 50000h@Tc=75°C			
	Noise	≤25dB(A)@20cm			
Surface	Dimension	227.4x68x39(LXWXH)mm			
	material	metal case			
Standards	Safety	GB19510. 1, GB19510. 14;IEC61347- 1, IEC61347-2- 13;AS/NZS 61347- 1, AS/NZS 61347-2- 13;AS 61347.2.13;EN62384;			

	EMC	GB/T17743, GB17625. 1;EN55015, EN61000-3-2, EN61000-3-3, EN61547;EN55015, EN61000-3-2, EN61000-3-3, EN61547,EN62493;EN61000-4-5;EN61000-4-2,3,4,5,6,8,11, EN61547
	ErP	ErP2.0 EU 2019/2020
	RoHS	RoHS (2011/65/EU) (EU)2015/863
Note	<p>1.All parameters NOT specially mentioned are measured at 230Vac input and 25°C of ambient temperature.</p> <p>2.Ripple & Noise are measured at 20MHz of bandwidth by using a 300mm twisted pair-wire terminated with a 0.1uF & 47 μF parallel capacitor.</p> <p>3.This LED driver meets the EMI specifications above, but EMI performance of a lighting fixture also depends on the other devices on the fixture.</p> <p>4.The IC setting protection logic is: many times quick switch will caused 1s delay to power on, the interval of start up time more 2s, will be power on normally.</p> <p>5.The LED driver complies with the IP67 (and lower) protection rating standards, but is only suitable for indoor damp environments or outdoor sheltered locations (e.g., with rain protection). All products must not be used underwater or buried in the ground.</p> <p>6.All Eaglerise power supply are complied with EMI regulations. Since they are belong to component and will be installed inside system enclosure. When they are integrated into a system, the EMI characteristics of the system must be re-verified again.</p>	

◆ Inrush Current

I _{peak}	T _{width}	B10	B16	B20	C10	C16	C20
47A	838μs	1pcs	3pcs	3pcs	3pcs	5pcs	6pcs

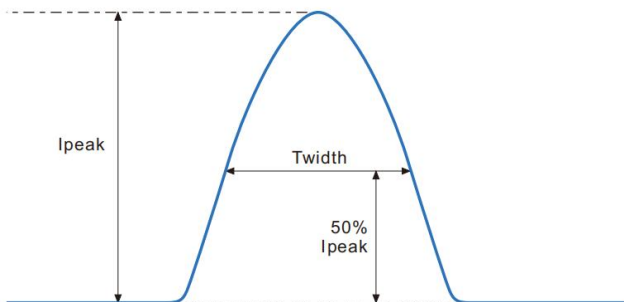

Remarks:

- 1.The number of drives mounted under different MCBs in the table is the maximum value. Please do not exceed this number during installation.
- 2.Different brands and models of miniature circuit breakers, the number of drives mounted will be slightly different.

◆ Wiring diagram

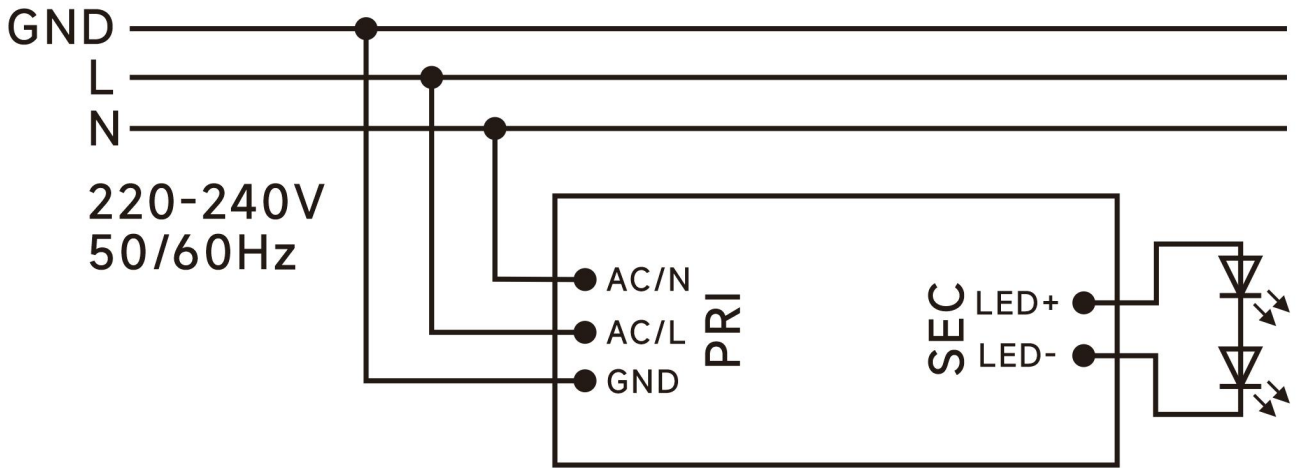

◆ 2D diagram

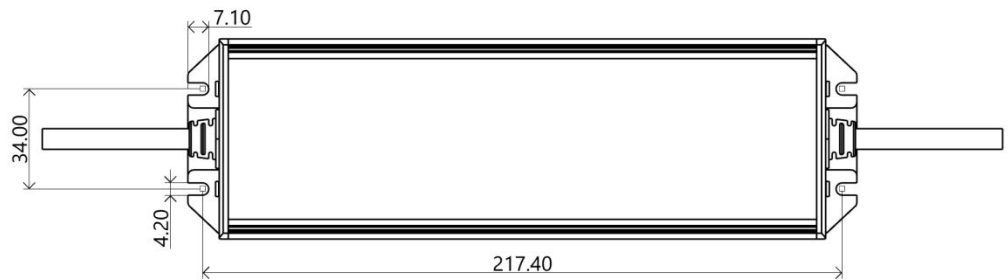
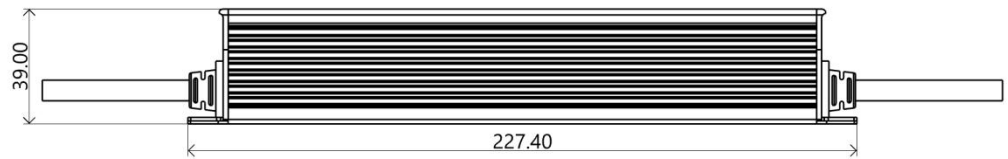
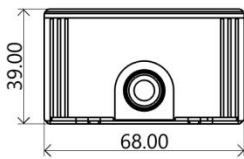

Model	TYPE	Total Length	Outside Color	Inside Wires Color	Wire Model/Diameter
VMS-320-XX IP67 L EXC	Input wire	300mm	Black	Brown/Blue/Yellow&Green	H05RN-F/3x1.0mm ²
VMS-320-24 IP67 L EXC	Output wire	300mm	Black	Red/Black	H05RN-F/2x1.5mm ²
VMS-320-36 IP67 L EXC	Output wire	300mm	Black	Red/Black	H05RN-F/2x1.5mm ²
VMS-320-42 IP67 L EXC	Output wire	300mm	Black	Red/Black	H05RN-F/2x1.0mm ²
VMS-320-48 IP67 L EXC	Output wire	300mm	Black	Red/Black	H05RN-F/2x1.0mm ²

Note: Wire length of input and output can be changed as customer's requirement

◆ Packaging

Model	Product Dimensions(mm)	weight/piece	Outer carton dimension(mm)	Quantity/carton	Net weight/carton(Kg)	Gross weight/carton(Kg)
VMS-320-XX IP67 L EXC	227.4x68x39	1.15	405X315X170	24	27.28	27.6

◆ Curve for VMS-320-XX IP67 L EXC

Lifetime vs. Temperature Curve

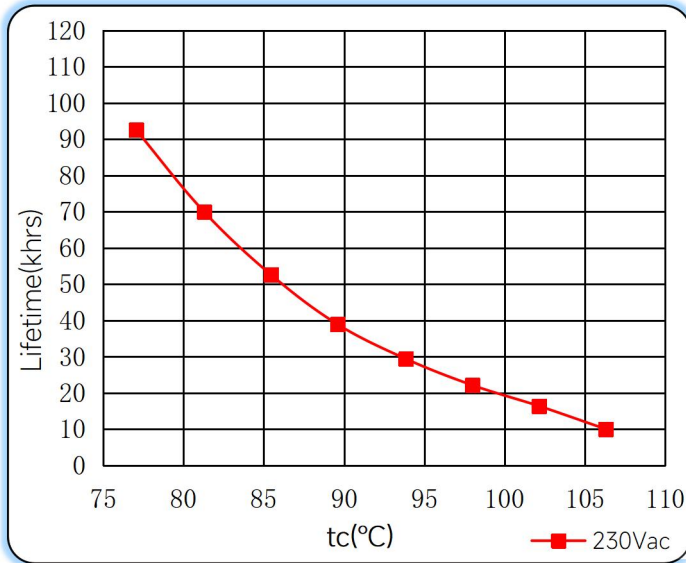

Efficiency vs. Load

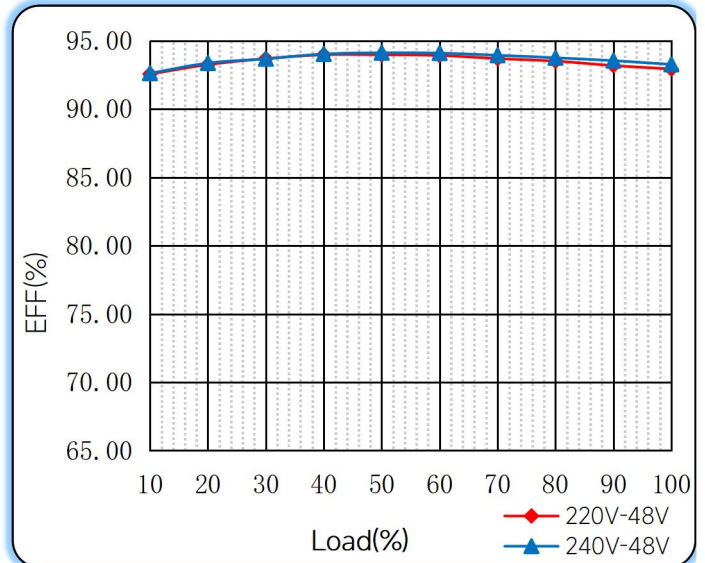

Power Factor Characteristics

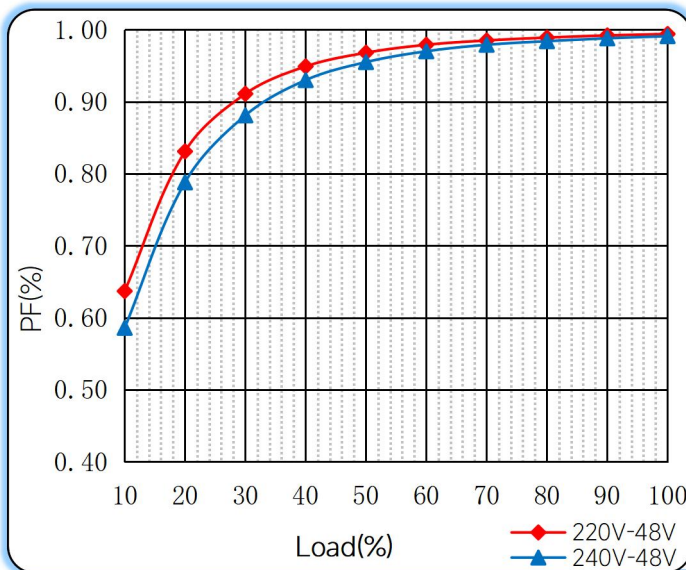

THD vs. Load

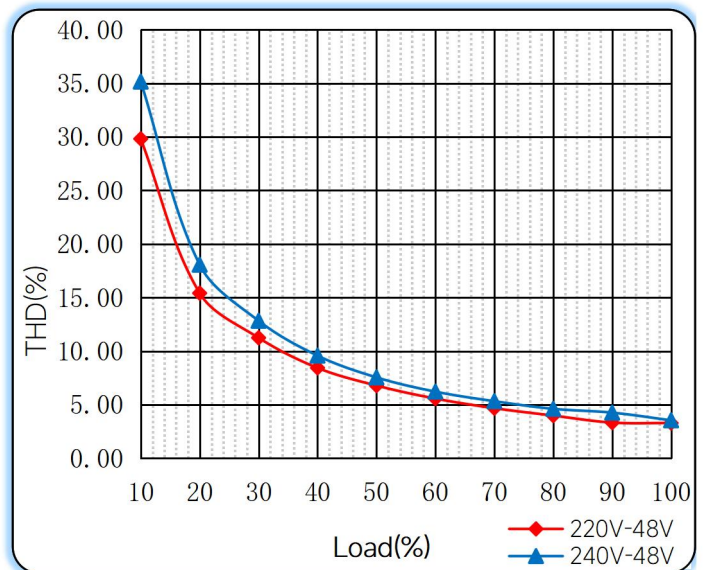

Load vs. Ta

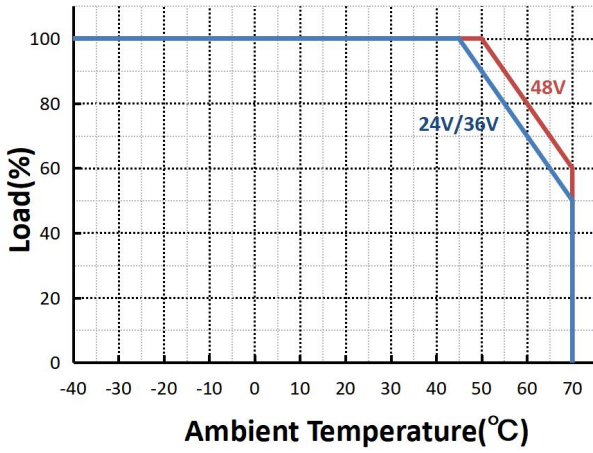

◆ Operating window

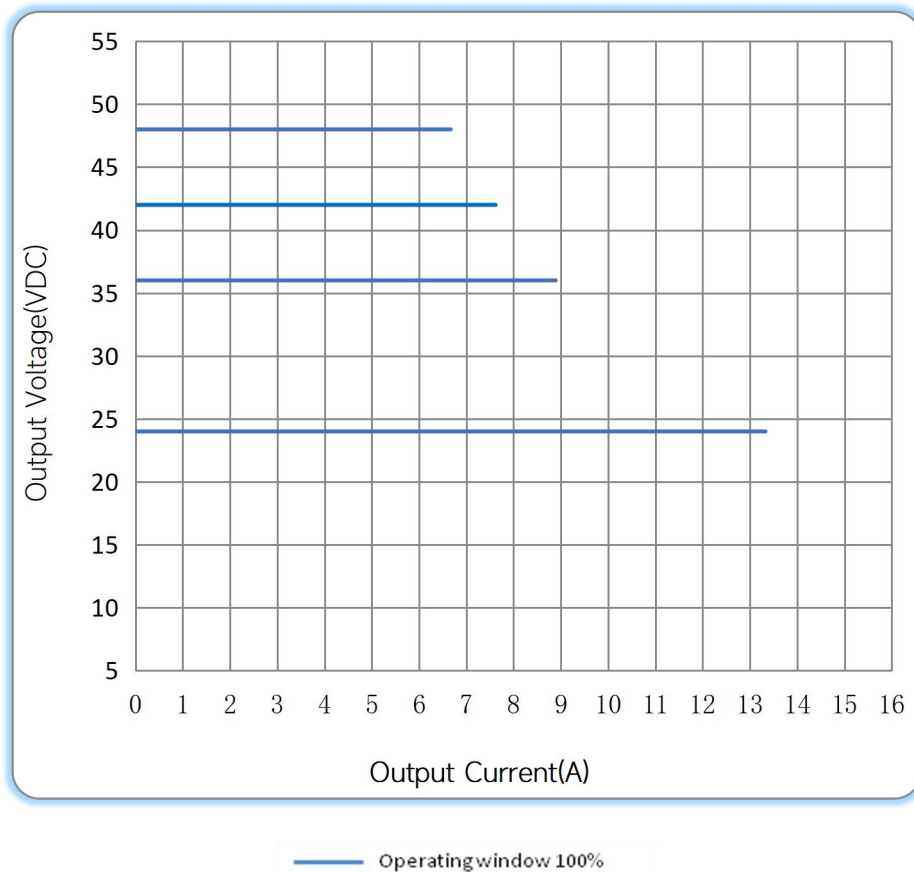

◆ Revision Updates

ITEM	BEFORE	AFTER	VERSION	DATE
Initial			A	2024/05/15
Operating Temperature	-40°C~+50°C	-40°C~+45°C	B	2024/12/10
Operating Temperature	-40°C~+45°C	-40°C~+50°C	C	2025/05/27
Operating Temperature	-40°C~+50°C	-40°C~+55°C	D	2025/06/05
Wiring diagram			E	2025/08/01

Remark: The final interpretation of the contents of the specification belongs to Eaglerise Electric & Electronic (China) Co., Ltd.

Tel: +86-0757-86256822, +86-0757-86256831

E-mail: sales@eaglerise.com

Website : <https://lighting.eaglerise.com>



EAGLERISE



Manual